

### Features:

- Economical
- +5 dBm Typical Output Power
- Low Power consumption
- 8μS Sweep with related band
- Small and Compact

### Description:

The RFTxSWV248-258-CD is a Sweeper, which operates in a Frequency Band of 2400MHz to 2500MHz. Output Power is +4 to +5 dBm Maximum (referenced to 50 Ω). This are used in various RF Testing Setup. Stability over temperature is ±0.5dB.

### Applications:

- Scientific equipment testing & manufacturing
- Signal Blocking
- EMC Test laboratories
- Antenna development, testing & calibrate Testing of shielding effectiveness
- equipment calibration
- Signal Jamming System

### Mechanical Dimension:

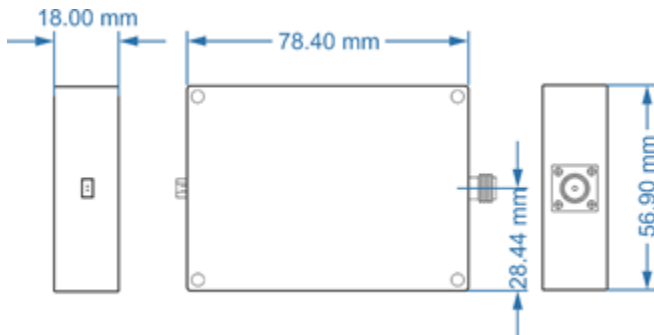

### Electrical Specifications:

Frequency Band:	2400 MHz - 2500 MHz
Center Frequency	2450 MHz
Output Power	+4 to +5 dBm
Sweep Time:	8 μs
Input Power Supply:	+9 to +48 VDC / 0.5A Max.
Power Connector:	JST-XHP-2 (M)
Operating Temperature:	-20 °C to +75 °C
Output Port:	SMA Female
Power Used:	1W (max)

### Mechanical Specifications:

Dimensions	78.4 mm X 56.9 mm X 18 mm (Excluding Connectors)
Shape:	Rectangle
Weight:	140 gm ± 10 gm

### Test Result:

